

Customer	--
Project	--

MARK	DATE	REV. RECORD	REV. BY	APPR. BY
△				
△				
△				

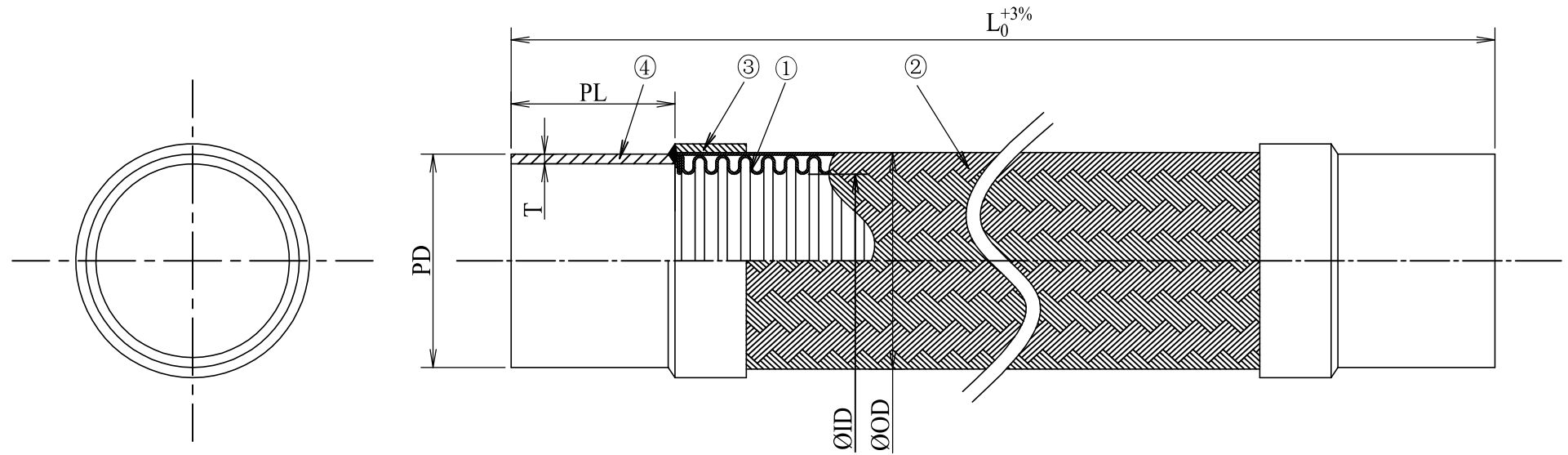

Size		Pipe			Tube		Le.	Q'ty	Weight
DN	Inch	PD	T	PL	ID	OD	L	Q	W(kg)
8	1/4	13.8	1.65	-	7.2	12.1	-	-	-
10	3/8	17.3	1.65	-	10.5	16.3	-	-	-
15	1/2	21.7	2.1	-	13.0	19.6	-	-	-
20	3/4	27.2	2.1	-	19.0	26.9	-	-	-
25	1	34.0	2.8	-	25.3	34.0	-	-	-
32	1-1/4	42.7	2.8	-	33.5	42.2	-	-	-
40	1-1/2	48.6	2.8	-	39.1	49.1	-	-	-
50	2	60.5	2.8	-	52.6	63.1	-	-	-

Size		Pipe			Tube		Le.	Q'ty	Weight
DN	Inch	PD	T	PL	ID	OD	L	Q	W(kg)
65	2-1/2	76.3	3.0	-	66.0	78.6	-	-	-
80	3	89.1	3.0	-	75.0	93.3	-	-	-
100	4	114.3	3.0	-	101.0	123.0	-	-	-
125	5	139.8	3.4	-	123.8	148.5	-	-	-
150	6	165.2	3.4	-	148.8	175.5	-	-	-
200	8	216.3	4.0	-	194.6	227.5	-	-	-
250	10	267.4	4.0	-	244.6	281.0	-	-	-
300	12	318.5	4.5	-	294.4	333.9	-	-	-

Note:

- 1.
- 2.
- 3.

10	-	-	-	-	Customer	-
9	-	-	-	-	Nominal Dia	DN8-300
8	-	-	-	-	Length	L--- mm
7	-	-	-	-	Fluid	-
6	-	-	-	-	Design press	1.0 Mpa
5	-	-	-	-	Design temper.	40 °C
4	End pipe	SUS304	2	SCH10	Hydraulic test	- Mpa
3	Braid sleeve	SUS304	2	-	Pneumatic test	1.1 Mpa
2	Braid	SUS304	1	1ply	Bend radius	- mm
1	Tube	SUS304	1	STD	Axial move	- mm
No	Parts name	Material	Q'ty	Remark	Lateral move	- mm

Product Name	NK-VN1400 Metallic Flexible Hose		
Projection method		Scale	Free
Date	Approved	Checked	Drawn
18/05/2022	-	Dat	Sang
A Member Of Nagoku Flexible Hose Industry NFK VIET NAM CO.,LTD			
Draw No	NFK-VN000***		