

Customer	--
Project	--

MARK	DATE	REV. RECORD	REV. BY	APPR. BY
△				
△				
△				

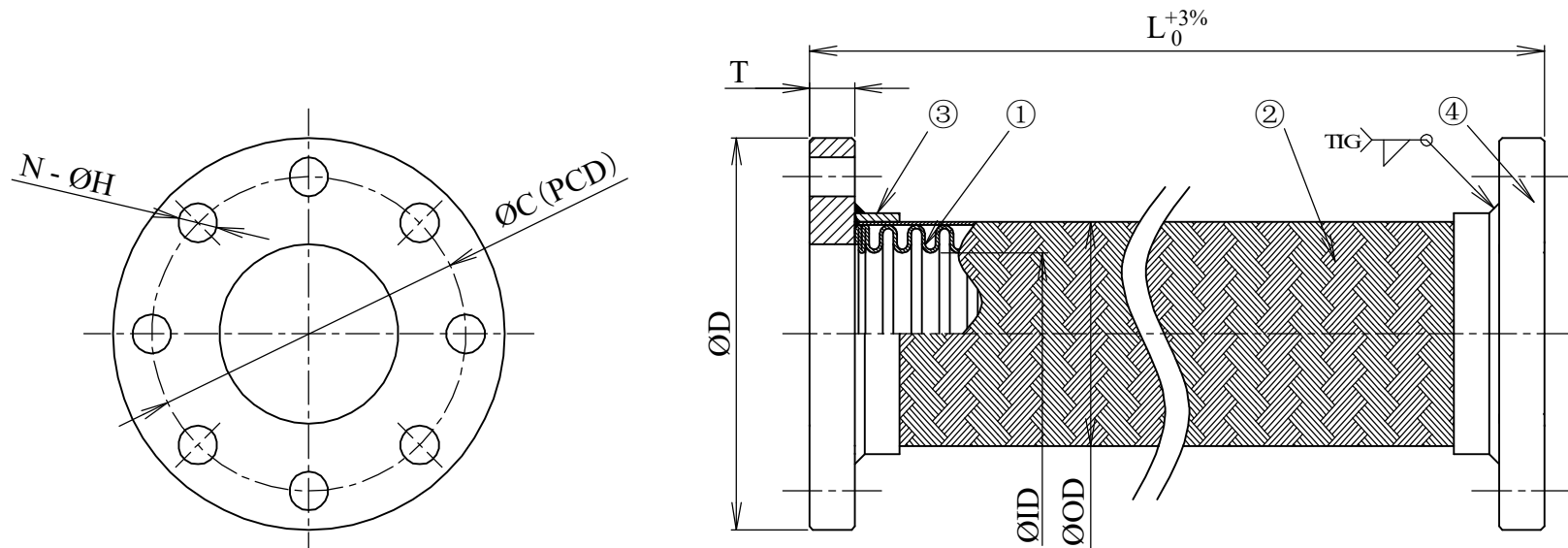

Note:

1. Flange : Cr3+ Gavanized
2. Burst test pressure : Min 6.4Mpa
3. With DN80-DN125, Use a braid that is one size larger.

Size	Flange				Tube/Braid			Length/Q'ty			
DN	D	C	T	N-H	ID	OD	Ply	L	Q	L	Q
20	105	75	16	4-14	19.0	26.9	1	300	-	500	-
25	115	85	16	4-14	25.3	34.0	1	300	-	500	-
32	140	100	16	4-18	33.5	42.2	1	300	-	500	-
40	150	110	16	4-18	39.1	49.1	1	300	-	500	-
50	165	125	18	4-18	52.6	63.1	1	300	-	500	-
65	185	145	18	4-18	66.0	78.6	1	300	-	500	-
80	200	160	20	8-18	75.0	93.3	1	300	-	500	-
100	220	180	20	8-18	101.0	123.0	1	300	-	500	-
125	250	210	22	8-18	123.8	148.5	1	300	-	500	-
150	285	240	22	8-22	148.8	175.5	1	300	-	500	-
200	340	295	24	12-22	194.6	230.5	2	300	-	500	-
250	405	355	26	12-26	244.6	287.0	2	300	-	500	-
300	460	410	28	12-26	294.4	337.8	2	300	-	500	-

10	-	-	-	-	Customer	-	Product Name	NK-VN3000EX Metallic Flexible Hose						
9	-	-	-	-	Nominal Dia	DN20-300	Projection method		Scale	Free	Date	Approved	Checked	Drawn
8	-	-	-	-	Length	L--- mm								
7	-	-	-	-	Fluid	-	Date	20/07/2021	N.Maeda	N.Maeda	Dat			
6	-	-	-	-	Design press	1.6 Mpa								
5	-	-	-	-	Design temper.	40 °C		A Member Of Nagoku Flexible Hose Industry						
4	Fixed flange	SS400	2	PN16 FF	Hydraulic test	2.4 Mpa		NFK VIET NAM CO.,LTD						
3	Braid sleeve	SUS304	2	-	Pneumatic test	1.1 Mpa	Draw No	NFK-VN000575-15						
2	Braid	SUS304	1	- ply	Bend radius	- mm								
1	Tube	SUS304	1	STD	Axial move	- mm								
No	Parts name	Material	Q'ty	Remark	Lateral move	10 mm								

Customer	--
Project	--

MARK	DATE	REV. RECORD	REV. BY	APPR. BY
\triangle^3	26/01/2022	Added size 350A	Dat	-
\triangle				
\triangle				

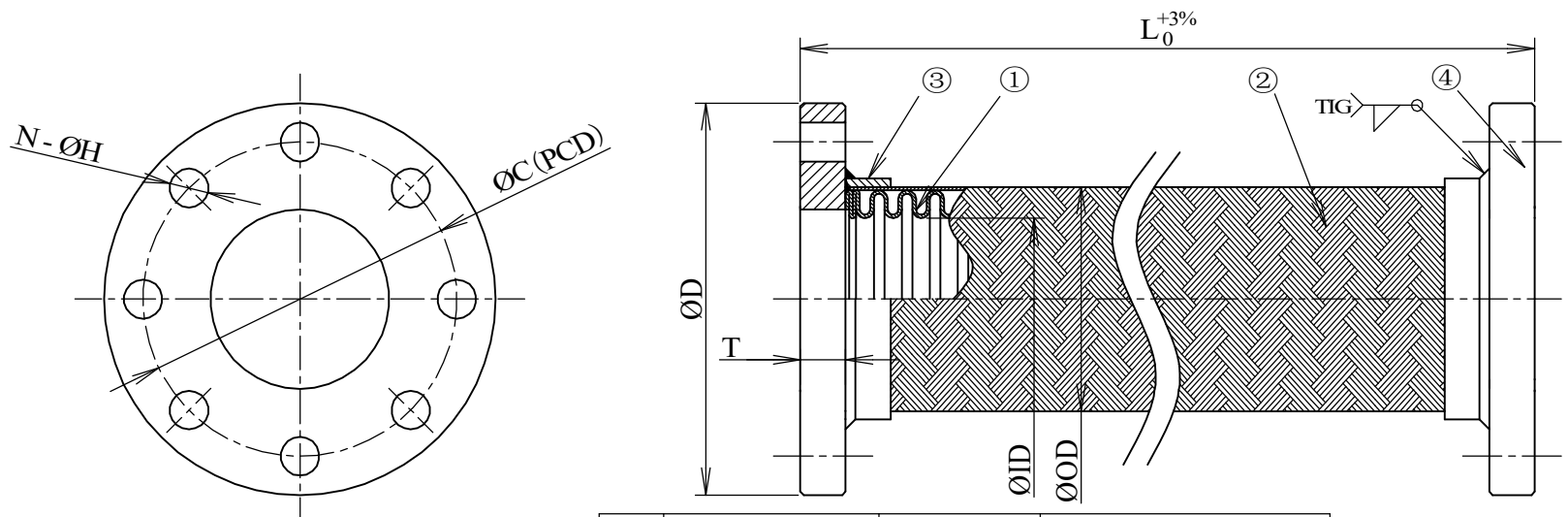

Note:

1. Flange : Cr3+ Gavanized
- 2.
- 3.

Size	Flange				Tube			Length / Q'ty				
	DN	D	C	T	N-H	ID	OD	Type	L	Q	L	Q
20	100	75	14	4-15	19.0	26.9	STD	300	-	500	-	-
25	125	90	14	4-19	25.3	34.0	STD	300	-	500	-	-
32	135	100	16	4-19	33.5	42.2	STD	300	-	500	-	-
40	140	105	16	4-19	39.1	49.1	STD	300	-	500	-	-
50	155	120	16	4-19	52.6	63.1	STD	300	-	500	-	-
65	175	140	18	4-19	66.0	78.6	STD	300	-	500	-	-
80	185	150	18	8-19	75.0	93.3	STD	300	-	500	-	-
100	210	175	18	8-19	101.0	123.0	STD	300	-	500	-	-
125	250	210	20	8-23	123.8	148.5	STD	300	-	500	-	-
150	280	240	22	8-23	148.8	175.5	STD	300	-	500	-	-
200	330	290	22	12-23	194.6	227.5	STD	300	-	500	-	-
250	400	355	24	12-25	244.6	281.0	STD	300	-	500	-	-
300	445	400	24	16-25	294.4	333.9	STD	300	-	500	-	-
350	490	445	26	16-25	336.6	381	SA	300	-	500	-	-

\triangle

10	-	-	-	-	Customer	-	Product Name	NK-VN3000EX Metallic Flexible Hose		
9	-	-	-	-	Nominal Dia	DN20-350 \triangle	Projection method		Scale	Free
8	-	-	-	-	Length	L--- mm	Date	Approved	Checked	Drawn
7	-	-	-	-	Fluid	-	23/08/2021	-	-	Dat
6	-	-	-	-	Design press	1.0 Mpa				
5	-	-	-	-	Design temper.	40 °C				
4	Fixed flange	SS400	2	JIS10K FF	Hydraulic test	- Mpa				
3	Braid sleeve	SUS304	2	-	Pneumatic test	1.1 Mpa				
2	Braid	SUS304	1	1 ply	Bend radius	- mm				
1	Tube	SUS304	1	-	Axial move	- mm				
No	Parts name	Material	Q'ty	Remark	Lateral move	10 mm	Draw No	NFK-VN000575-16-R1 \triangle		



A Member Of Nagoku Flexible Hose Industry
NFK VIET NAM CO.,LTD