

Customer	--
Project	--

MARK	DATE	REV. RECORD	REV. BY	APPR
△				
△				
△				

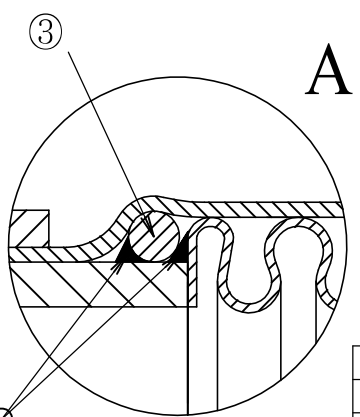
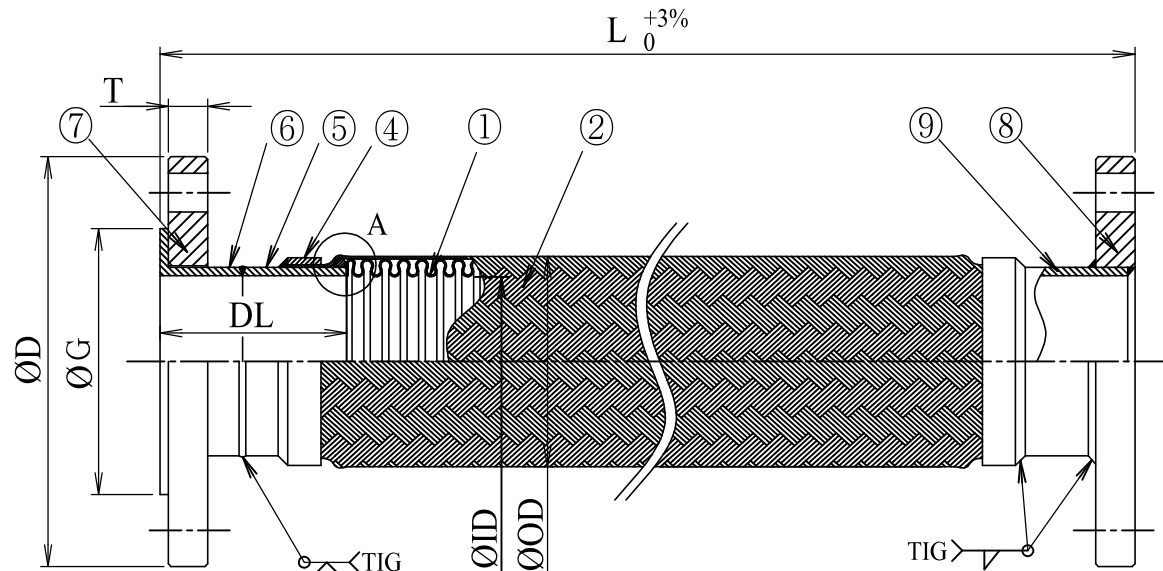
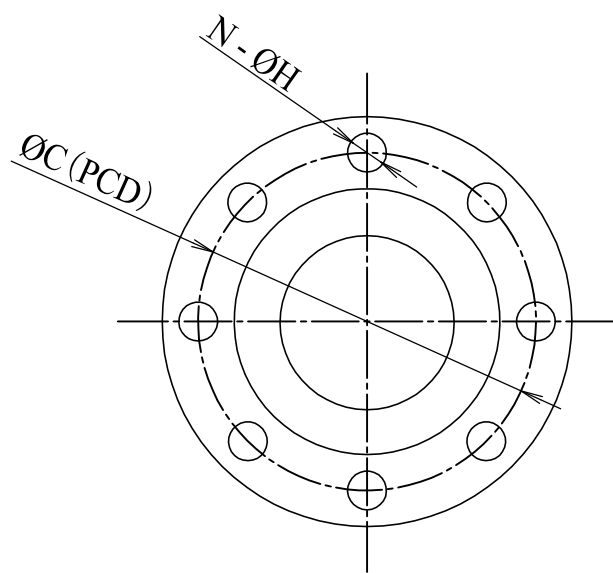

Size		Lap joint		Flange				Tube		Length	Q'ty	Weight
DN	Inch	G	DL	D	C	T	N-H	ID	OD	L	Q	W(kg)
50	2	96	100	155	120	16	4-19	54.0	72.1	300~	-	-
65	2-1/2	116	100	175	140	18	4-19	67.0	87.6	300~	-	-
80	3	126	100	185	150	18	8-19	79.0	102.5	400~	-	-
100	4	151	100	210	175	18	8-19	103.0	128.0	400~	-	-
125	5	182	120	250	210	20	8-23	129.0	156.5	500~	-	-
150	6	212	120	280	240	22	8-23	153.0	183.5	500~	-	-
200	8	262	140	330	290	22	12-23	199.0	233.0	500~	-	-
250	10	324	150	400	355	24	12-25	250.8	288.0	500~	-	-
300	12	368	160	445	400	24	16-25	300.8	339.0	500~	-	-
350	14	413	160	490	445	26	16-25	336.6	381.0	500~	-	-

10	-	-	-	-	Customer	-	Product Name	NK-VN5500 Metallic Flexible Hose			
9	Pipe 2	SUS304/SGP	1	SCH10	Nominal Dia	DN50~350	Projection method		Scale	Fre	
8	Fixed flange	SUS304/SS400	1	JIS10K FF	Length	L300~ mm	Date	Approved	Checked	Draw	
7	Loosen flange	SUS304/SS400	1	JIS10K FF	Fluid	-	17/05/2022	-	Dat	Sar	
6	Lap joint	SUS304/STPG370	1	SCH10	Design press	1.0 Mpa					
5	Pipe 1	SUS304/SGP	1	SCH10	Design temper.	40 °C					
4	Braid sleeve	SUS304	2	-	Hydraulic test	- Mpa					
3	Neck ring	SUS304	2	-	Pneumatic test	1.1 Mpa					
2	Braid	SUS304	1	1 ply	Bend radius	- mm					
1	Tube	SUS304	1	SA	Axial move	- mm					
No	Parts name	Material	Q'ty	Remark	Lateral move	- mm	Draw No	NFK-VN000***			

TIG

Note:

- 1.
- 2.
- 3.



A Member Of Nagoku Flexible Hose Indus
NFK VIET NAM CO.,LTD