

Customer	--
Project	--

MARK	DATE	REV. RECORD	REV. BY	APPR. BY
△				
△				
△				

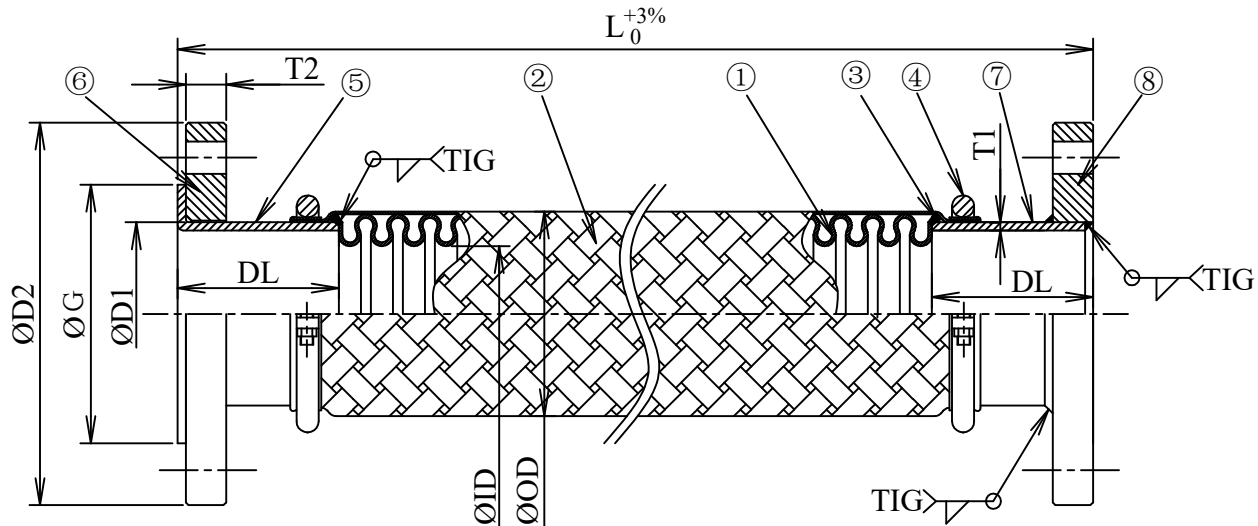
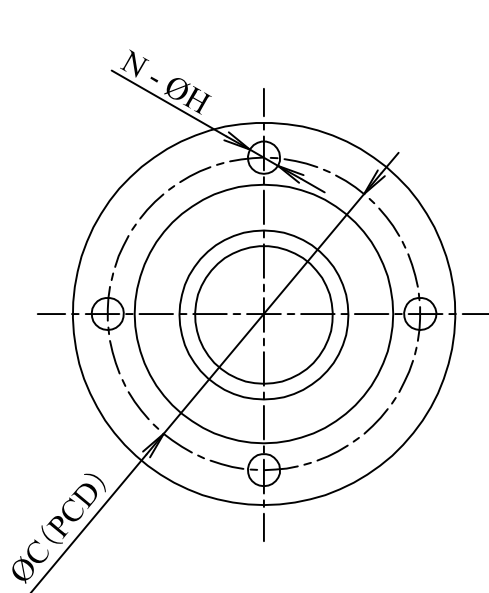

Size		Lap joint				Flange				Tube		Length	Q'ty
DN	Inch	G	D1	T1	DL	D2	C	T2	N-H	ID	OD	L	Q
80	3	126	89.1	3.0	100	185	150	18	8-19	79.0	102.5	400~	-
100	4	151	114.3	3.0	100	210	175	18	8-19	103.0	128.0	400~	-
125	5	182	139.8	3.4	120	250	210	20	8-23	129.0	156.5	500~	-
150	6	212	165.2	3.4	120	280	240	22	8-23	153.0	183.5	500~	-
200	8	262	216.3	4.0	140	330	290	22	12-23	199.0	233.0	500~	-
250	10	324	267.4	4.0	140	400	355	24	12-25	250.8	288.0	500~	-
300	12	368	318.5	4.5	160	445	400	24	16-25	300.8	339.0	500~	-
350	14	413	355.6	5.0	160	490	445	26	16-25	336.6	381.0	500~	-
400	16	475	406.4	5.0	180	560	510	28	16-27	385.0	440.0	500~	-
450	18	530	457.2	5.0	180	620	565	30	20-27	435.0	490.0	600~	-
500	20	585	508.0	5.5	180	675	620	30	20-27	485.0	540.0	600~	-
550	22	640	558.8	5.5	180	745	680	32	20-33	535.0	590.0	600~	-
600	24	690	609.6	6.5	180	795	730	32	24-23	585.0	640.0	600~	-

Note:

- 1.
- 2.
- 3.

10	-	-	-	-	-	Customer	-	Product Name	NK-VN5000 Metallic Flexible Hose			
9	-	-	-	-	-	Nominal Dia	DN80~600	Projection method		Scale	Free	
8	Fixed flange	SUS304/SS400	1	JIS10K SOPFF	Length	L400~	mm	Date	Approved	Checked	Drawn	
7	Pipe	SUS304/SGP	1	SCH10	Fluid	-		17/05/2022	-	Dat	Sang	
6	Loose flange	SUS304/SS400	1	JIS10K SOPFF	Design press	1.0	Mpa					
5	Lap joint	SUS304	1	SCH10	Design temper.	40	°C					
4	Band	SS400	2	-	Hydraulic test	-	Mpa					
3	Neck ring	SUS304	2	-	Pneumatic test	1.1	Mpa					
2	Braid	SUS304	1	1ply	Bend radius	-	mm					
1	Tube	SUS304	1	SA	Axial move	-	mm					
No	Parts name	Material	Q'ty	Remark	Lateral move	-	mm	Draw No	NFK-VN000***			

A Member Of Nagoku Flexible Hose Industry
NFK VIET NAM CO.,LTD