

Customer	--
Project	--

MARK	DATE	REV. RECORD	REV. BY	APPR. BY
△				
△				
△				

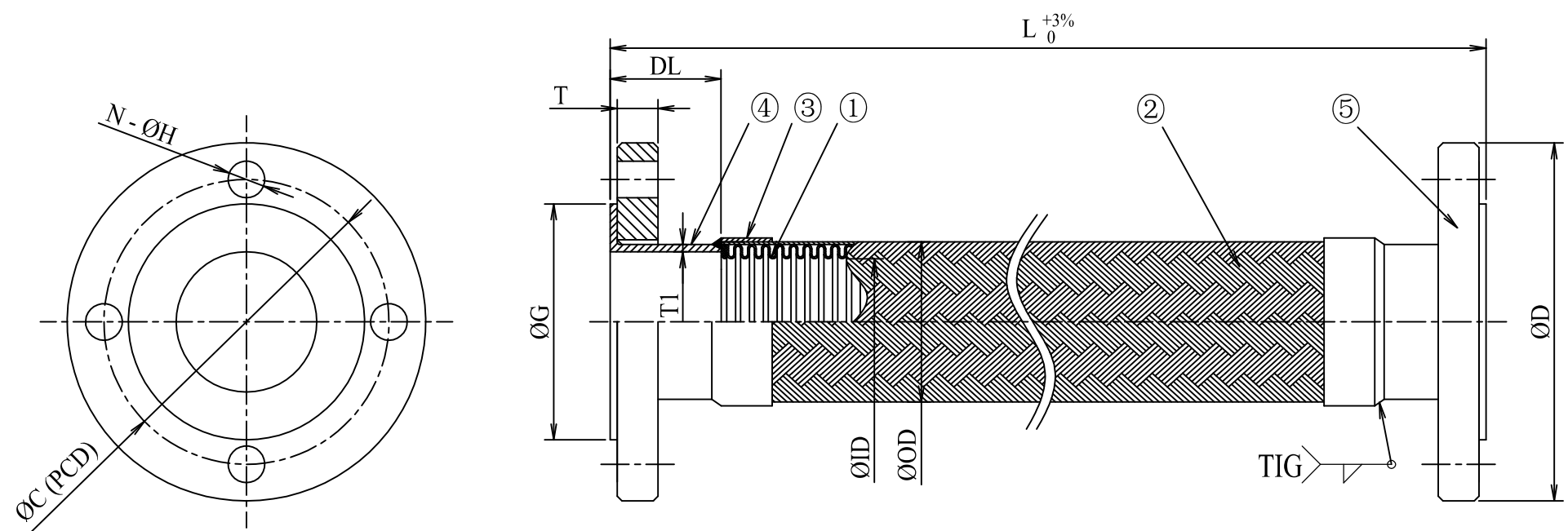

Size		Lap joint			Flange				Tube		Length./Q'ty	
DN	Inch	G	T1	DL	D	C	T	N-H	ID	OD	L	Q
15	1/2	51	2.1	30	95	70	12	4-15	13.0	19.6	200~	-
20	3/4	56	2.1	30	100	75	14	4-15	19.0	26.9	200~	-
25	1	67	2.8	50	125	90	14	4-19	25.3	34	200~	-
32	1-1/4	76	2.8	50	135	100	16	4-19	33.5	42.2	200~	-
40	1-1/2	81	2.8	50	140	105	16	4-19	39.1	49.1	200~	-
50	2	96	2.8	50	155	120	16	4-19	52.6	63.1	200~	-
65	2-1/2	116	3.0	50	175	140	18	4-19	66.0	78.6	200~	-
80	3	126	3.0	50	185	150	18	8-19	75.0	93.3	200~	-
100	4	151	3.0	50	210	175	18	8-19	101.0	123.0	200~	-

Size		Lap joint			Flange				Tube		Length./Q'ty	
DN	Inch	G	T1	DL	D	C	T	N-H	ID	OD	L	Q
125	5	182	3.4	50	250	210	20	4-15	123.8	148.5	300~	-
150	6	212	3.4	50	280	240	22	4-15	148.8	175.5	300~	-
200	8	262	4.0	65	330	290	22	4-19	194.6	227.5	300~	-
250	10	324	4.0	65	400	355	24	4-19	244.6	281	300~	-
300	12	368	4.5	65	445	400	24	4-19	294.4	333.9	400~	-

**Note:**

- 1.
- 2.
- 3.

10	-	-	-	-	Customer	-	Product Name	NK-VN2600 Metallic Flexible Hose			
9	-	-	-	-	Nominal Dia	DN15~300	Projection method			Scale	Free
8	-	-	-	-	Length	L200~ mm		Date	Approved	Checked	Drawn
7	-	-	-	-	Fluid	-	25/05/2022	-	Dat	Sang	
6	-	-	-	-	Design press	1.0 Mpa	A Member Of Nagoku Flexible Hose Industry <b>NFK VIET NAM CO.,LTD</b>				
5	Loose flange	SS400/SUS304	2	JIS 10K FF	Design temper.	40 °C					
4	Lap joint	SUS304	2	SCH10	Hydraulic test	- Mpa					
3	Braid sleeve	SUS304	2	-	Pneumatic test	1.1 Mpa					
2	Braid	SUS304	1	1 ply	Bend radius	- mm					
1	Tube	SUS304	1	STD	Axial move	- mm	Draw No	NFK-VN000***			
No	Parts name	Material	Q'ty	Remark	Lateral move	- mm					