

Customer	-
Project	--

MARK	DATE	REV. RECORD	REV. BY	APPR.
△				
△				
△				

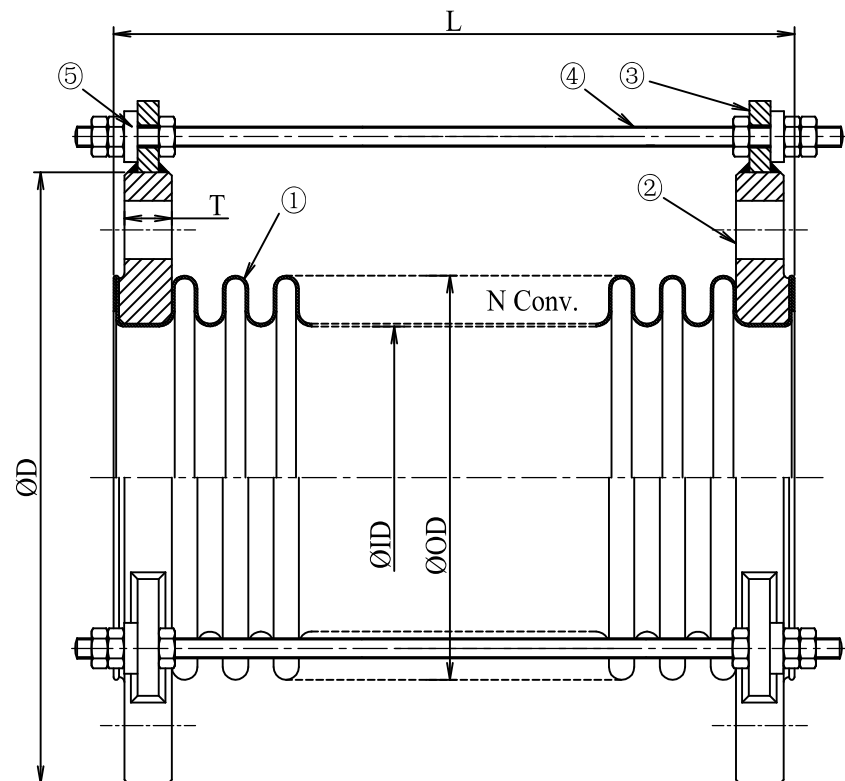
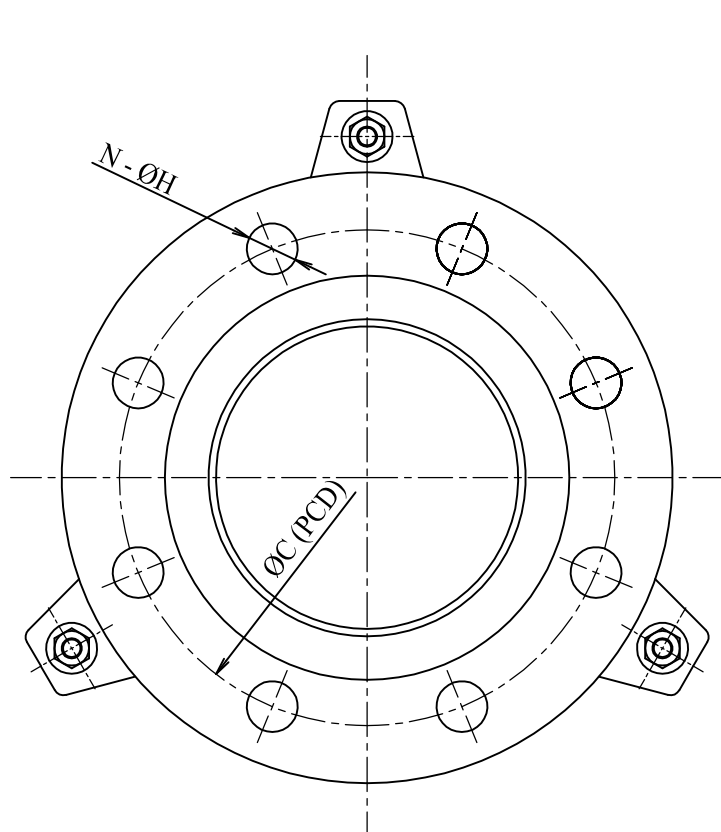

**Note:**

1. The model is used to vibration absorption.
- 2.
- 3.

Nominal Dia		Flange				Bellows			Length	Q'ty
DN	Inch	D	C	T	N-H	ID	OD	N	L	Q
50	2	155	120	18	8-19	59.1	73.5	7	110	-
65	2-1/2	175	140	20	8-19	74.9	90.5	6	110	-
80	3	200	160	22	8-23	87.3	107.3	6	110	-
100	4	225	185	24	8-23	112.5	132.5	7	150	-
125	5	270	225	26	8-25	137.5	157.5	7	150	-
150	6	305	260	28	12-25	162.8	187.2	6	150	-
200	8	350	305	30	12-25	214.1	238.5	9	200	-
250	10	430	380	34	12-27	264.8	292.6	8	200	-
300	12	480	430	36	16-27	315.7	342.5	7	200	-

10	-	-	-	-	Customer	-	Product Name	NK-7800			
9	-	-	-	-	Nominal Dia	DN50~300	Bellows Type Expansion Joint				
8	-	-	-	-	Length	L---	mm	Projection method		Scale	Free
7	-	-	-	-	Fluid	-	-	Date	20/05/2022	Approved	Checked
6	-	-	-	-	Design press	2.0	Mpa	-	-	Dat	San
5	Cushion	Resin	6	-	Design tem.	40	°C	-	-	-	-
4	Tie rods	SS400	3	M-	Hydro test	-	Mpa	-	-	-	-
3	Holder	SS400	6	-	Pneum. test	-	Mpa	-	-	-	-
2	Flange	SUS304/SS400	2	JIS20K	Bend radius	-	mm	-	-	-	-
1	Bellows	SUS304+316L	1	7820 Bellows - 2 plies	Axial move	-	mm	-	-	-	-
No	Parts name	Material	Q'ty	Remark	Lateral move	-	mm	Draw No	NFK-VN000***		

A Member Of Nagoku Flexible Hose Indus  
NFK VIET NAM CO.,LTD