

| | |
|----------|----|
| Customer | - |
| Project | -- |

| MARK | DATE | REV. RECORD | REV. BY | APPR. |
|------|------|-------------|---------|-------|
| △ | | | | |
| △ | | | | |
| △ | | | | |

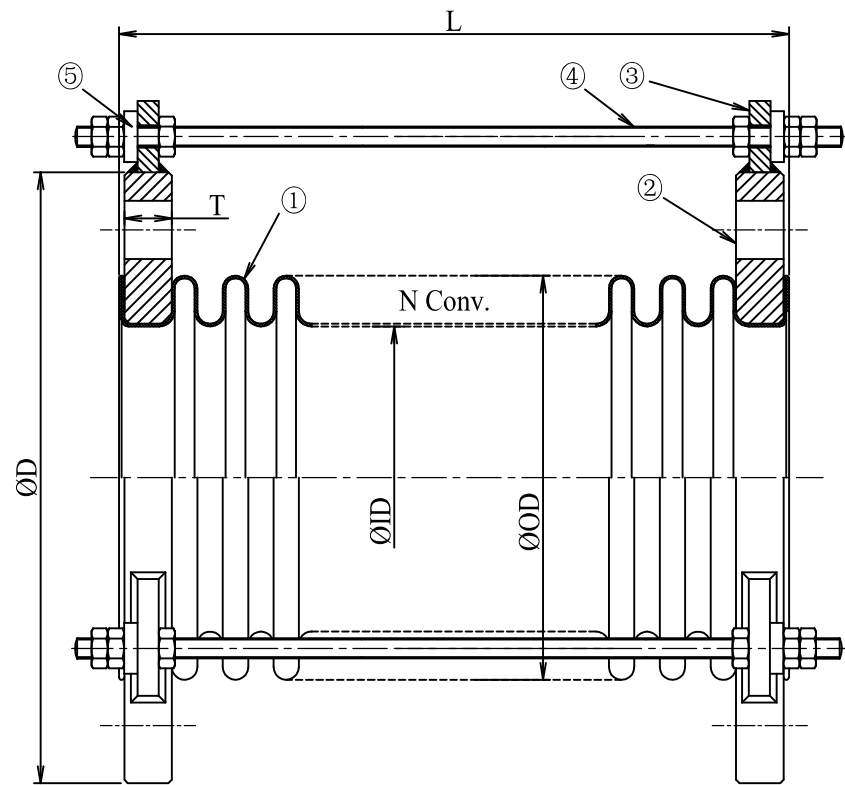
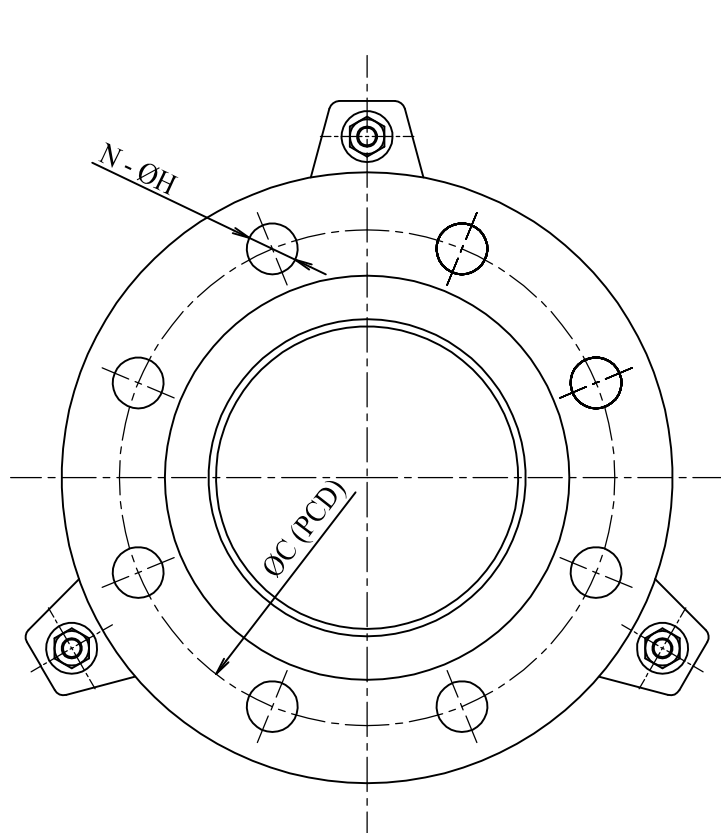

| Nominal Dia | | Flange | | | | Bellows | | | Length | Q'ty |
|-------------|-------|--------|-----|----|-------|---------|-------|----|--------|------|
| DN | Inch | D | C | T | N-H | ID | OD | N | L | Q |
| 50 | 2 | 155 | 120 | 16 | 4-19 | 59.5 | 73.5 | 18 | 150 | - |
| 65 | 2-1/2 | 175 | 140 | 18 | 4-19 | 75.0 | 89.0 | 16 | 150 | - |
| 80 | 3 | 185 | 150 | 18 | 8-19 | 88.0 | 104.2 | 16 | 150 | - |
| 100 | 4 | 210 | 175 | 18 | 8-19 | 113.0 | 129.2 | 16 | 150 | - |
| 125 | 5 | 250 | 210 | 20 | 8-23 | 138.0 | 158.6 | 12 | 150 | - |
| 150 | 6 | 280 | 240 | 22 | 8-23 | 163.5 | 184.1 | 12 | 150 | - |
| 200 | 8 | 330 | 290 | 22 | 12-23 | 214.7 | 242.7 | 12 | 200 | - |
| 250 | 10 | 400 | 355 | 24 | 12-25 | 265.8 | 293.8 | 12 | 200 | - |
| 300 | 12 | 445 | 400 | 24 | 16-25 | 316.9 | 344.9 | 12 | 200 | - |

Note:

1. The model is used to vibration absorption
- 2.
- 3.

| | | | | | | | | | | | |
|----|------------|--------------|------|------------------------|--------------|----------|------------------------------|-------------------|--------------|---------|------|
| 10 | - | - | - | - | Customer | - | Product Name | NK-7800 | | | |
| 9 | - | - | - | - | Nominal Dia | DN50-300 | Bellows Type Expansion Joint | | | | |
| 8 | - | - | - | - | Length | L--- | mm | Projection method | | Scale | Free |
| 7 | - | - | - | - | Fluid | - | Date | 20/05/2022 | Approved | Checked | Draw |
| 6 | - | - | - | - | Design press | 1.0 | Mpa | - | - | Dat | San |
| 5 | Cushion | Resin | 6 | - | Design tem. | 40 | °C | - | - | - | - |
| 4 | Tie rods | SS400 | 3 | M- | Hydro test | - | Mpa | - | - | - | - |
| 3 | Holder | SS400 | 6 | - | Pneum. test | - | Mpa | - | - | - | - |
| 2 | Flange | SS400/SUS304 | 2 | JIS10K | Bend radius | - | mm | - | - | - | - |
| 1 | Bellows | SUS304+316L | 1 | 7810 Bellows - 2 plies | Axial move | - | mm | - | - | - | - |
| No | Parts name | Material | Q'ty | Remark | Lateral move | - | mm | Draw No | NFK-VN000*** | | |