

Customer	--
Project	--

MARK	DATE	REV. RECORD	REV. BY	APPR. BY
△				
△				
△				

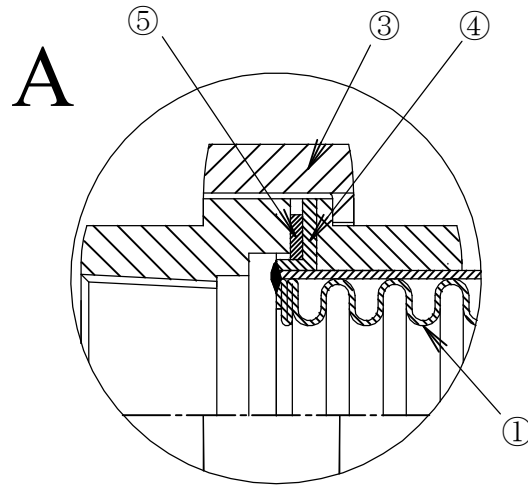
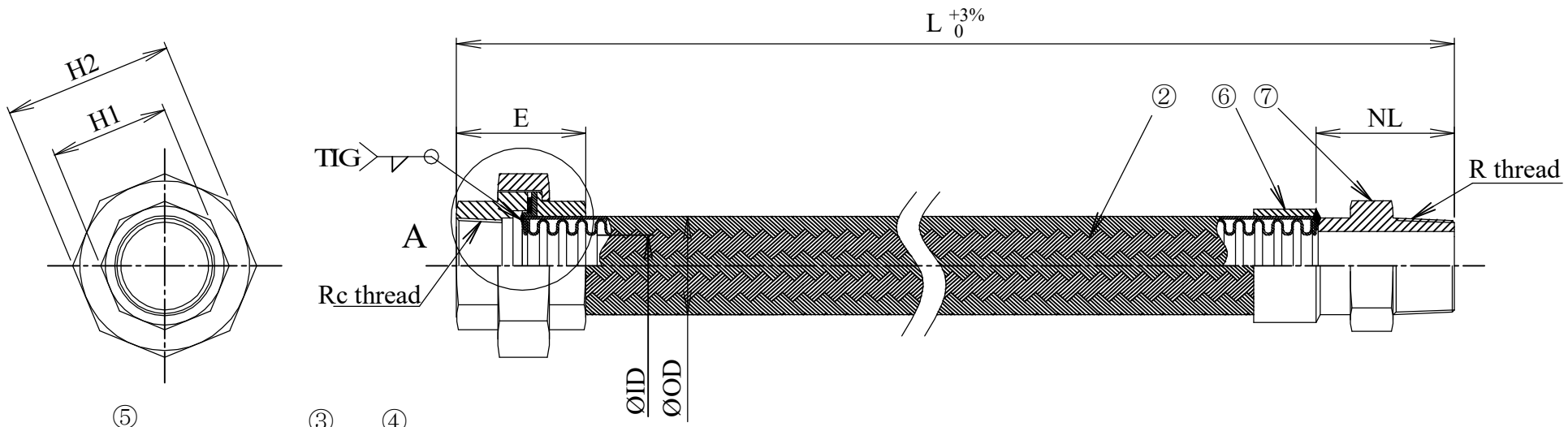

Size		Union				Tube		Nipple		Length/Q'ty			
DN	Inch	H1	H2	Rc	E	ID	OD	R	NL	L	Q	L	Q
15	1/2	27	42	1/2	40	13.0	19.6	1/2	36	300	-	500	-
20	3/4	33	49	3/4	48	19.0	26.9	3/4	38	300	-	500	-
25	1	41	59	1	52	25.3	34.0	1	40	300	-	500	-
32	1-1/4	50	69	1-1/4	56	33.5	42.2	1-1/4	47	300	-	500	-
40	1-1/2	56	78	1-1/2	60	39.1	49.1	1-1/2	49	300	-	500	-
50	2	69	93	2	67	52.6	63.1	2	56	300	-	500	-

Note:

- 1.
- 2.
- 3.

10	-	-	-	-	Customer	-	Product Name	NK-VN1900 Metallic Flexible Hose						
9	-	-	-	-	Nominal Dia	DN15-50	Projection method		Scale	Free	Date	Approved	Checked	Drawn
8	-	-	-	-	Length	L--- mm	Fluid	-	Design press	1.0 Mpa	01/04/2021	-	Dat	Linh
7	Nipple	SCS13	1	BSPT - R	Hydraulic test	- Mpa	Design temper.	40 °C	Pneumatic test	1.1 Mpa	A Member Of Nagoku Flexible Hose Industry NFK VIET NAM CO.,LTD			
6	Braid sleeve	SUS304	1	-	Bend radius	- mm	Hydraulic test	- Mpa	Axial move	- mm				
5	Gasket	PTFE	1	-	Lateral move	10 mm	Design press	1.0 Mpa	Design temper.	40 °C				
4	Collar	SUS304	1	-	Draw No	NFK-VN000575-8	Design press	1.0 Mpa	Design temper.	40 °C				
3	Union	SCS13	1	BSPT - Rc	Product Name	NK-VN1900	Design press	1.0 Mpa	Design temper.	40 °C				
2	Braid	SUS304	1	1ply	Product Name	Metallic Flexible Hose	Design press	1.0 Mpa	Design temper.	40 °C				
1	Tube	SUS304	1	STD	Product Name	Metallic Flexible Hose	Design press	1.0 Mpa	Design temper.	40 °C				
No	Parts name	Material	Qty	Remark	Product Name	Metallic Flexible Hose	Design press	1.0 Mpa	Design temper.	40 °C				

Customer	--
Project	--

MARK	DATE	REV. RECORD	REV. BY	APPR. BY
△				
△				
△				

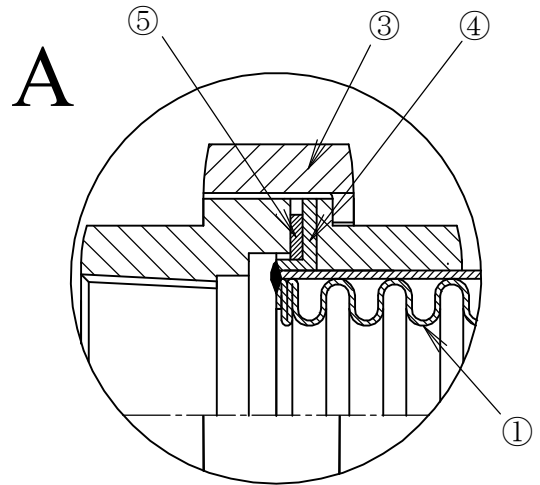
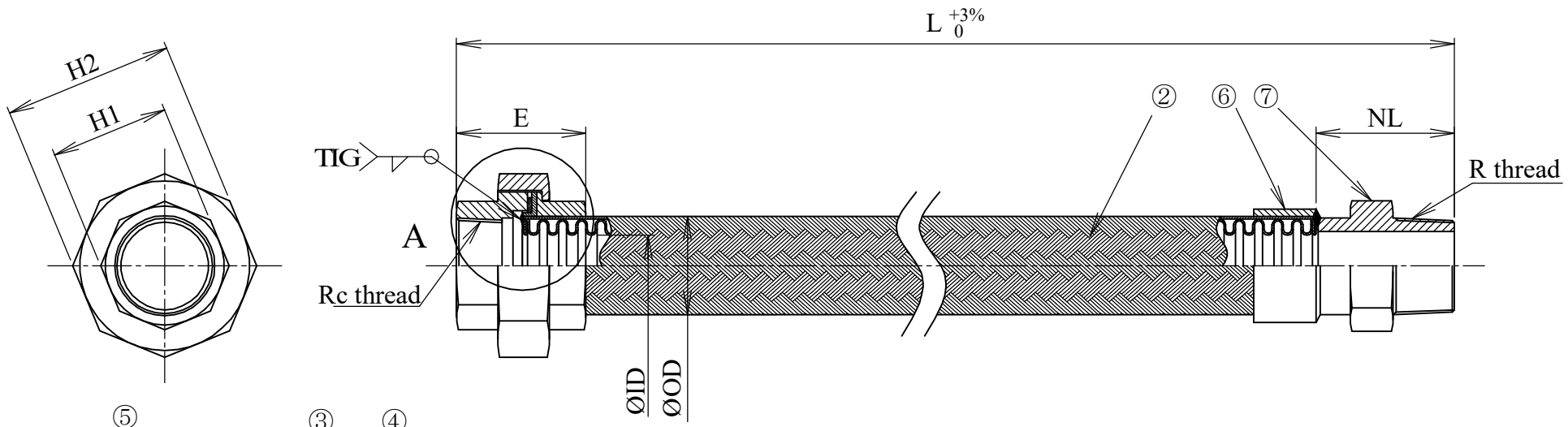

Size		Union				Tube		Nipple		Length/Q'ty			
DN	Inch	H1	H2	Rc	E	ID	OD	R	NL	L	Q	L	Q
15	1/2	27	42	1/2	40	13.0	19.6	1/2	36	300	-	500	-
20	3/4	33	49	3/4	48	19.0	26.9	3/4	38	300	-	500	-
25	1	41	59	1	52	25.3	34.0	1	40	300	-	500	-
32	1-1/4	50	69	1-1/4	56	33.5	42.2	1-1/4	47	300	-	500	-
40	1-1/2	56	78	1-1/2	60	39.1	49.1	1-1/2	49	300	-	500	-
50	2	69	93	2	67	52.6	63.1	2	56	300	-	500	-

Note:

- 1.
- 2.
- 3.

10	-	-	-	-	Customer	-	Product Name	NK-VN1900 Metallic Flexible Hose						
9	-	-	-	-	Nominal Dia	DN15-50	Projection method		Scale	Free	Date	Approved	Checked	Drawn
8	-	-	-	-	Length	L--- mm	Date	11/10/2021	-	Dat	Sang			
7	Nipple	SS400	1	BSPT - R	Fluid	-	Design press	1.0	Mpa					
6	Braid sleeve	SUS304	1	-	Design temper.	40	°C							
5	Gasket	Non-asbestos	1	T-#1995	Hydraulic test	-	Mpa							
4	Collar	SUS304	1	-	Pneumatic test	1.1	Mpa							
3	Union	FCMB	1	BSPT - Rc	Bend radius	-	mm							
2	Braid	SUS304	1	1ply	Axial move	-	mm							
1	Tube	SUS304	1	STD	Lateral move	10	mm							
No	Parts name	Material	Qty	Remark	Draw No	NFK-VN000575-19								

A Member Of Nagoku Flexible Hose Industry
NFK VIET NAM CO.,LTD